

## Convect-Rite® Tray Carts

Models: CR3C20, CR3C24, CR3C26 and CR3C30

Convect-Rite® carts are lightweight, attractive, durable and quiet. Designed specifically to mate with Convect-Rite® docking stations, their modern design has a “front-of-the-house” look, with “back-of-the-house” strength and durability.

The Convect-Rite® system was created to maximize operations flexibility and simplicity—all in a sleek, stainless steel cabinet. Convect-Rite’s® convection rethermalization process enhances food quality, presentation and the ability to expand menu choices.

Cold-plated meals are placed in the Convect-Rite® cart, which is then mated with the docking station. Meals are stored under forced-convection cold air refrigeration until the rethermalization process begins. Just prior to mealtime, hot air is circulated around foods to be served hot; cold air continues to surround and maintain cold foods.

The end result is delicious, appetizing meals served at ideal temperatures. Aladdin Temp-Rite’s advanced technology makes the process safe, simple and highly cost effective.

Versatile Convect-Rite® carts will house both divided and large symmetrical trays. When trays are placed in the cart, or removed, the gravity-activated Auto-Therm Seal immediately creates a tight seal securely against the tray or center panel to ensure that proper temperatures are maintained.

The center panel provides an insulating barrier that separates hot and cold foods. This enables individual meals to be gently reheated, while keeping cold items perfectly chilled.



Aladdin's Auto-Therm Seal prevents temperature migration, even when no tray is present.

Many types of dishware can also be used, so meal presentations can be customized for your facility.

The secure fit of Convect-Rite® carts with their docking stations ensures that meals are completely rethermalized and chilled within a 45-60 minute cycle.

### Great for cook-serve boost applications!

Need greater temperature hold-time for your cook-serve operations? Use Convect-Rite® systems for a boost! Assemble your meals via trayline on Convect-Rite® trays, load them into Convect-Rite® carts, then connect the carts to the docking station. A short *BOOST* cycle will improve hot and cold food temperatures prior to serving.



Do more with the Convect-Rite® system! It combines precision heat convection and refrigeration — all in one unit.

### Standard Features

#### Design/Construction

- 20/24 and 26/30 meal capacity carts
- Durable stainless steel tank, frame and doors
- High impact, non-marking polymer top and base
- Molded-in galley rail included in polymer cart top
- Polished cast-aluminum handle brackets, hinges, latch and strike covers

#### Performance

- Patented, directed airflow technology for uniform temperatures at each tray level
- Insulated walls, top, base, doors and center panel
- Space-age center panel insulation ensures temperature integrity
- Thermal break built into cart tank prevents temperature migration

#### Ease of Use

- Gravity operated Auto-Therm seal when no tray is present
- Large symmetrical trays or divided trays are available
- Large 6.3" (16 cm) non-marking casters provide easy pushing and maneuverability (2 fixed, 2 swivel with locks)
- Flush-mounted paddle latches provide “hands-free” slam-latch door closing
- ID holder for cart identification

#### Cleaning

- Can be hand or hose-washed or placed into automatic cart wash (see Section III, page 7 of Owner's Manual)
- Lift-out, easily removable tray guides
- Auto-Therm seal is easy to remove (without tools) and clean in dishwasher

Convect-Rite III® Rethermalization system U.S. Patent No. 7,025,121

# Convect-Rite® Tray Carts

## Models: CR3C20, CR3C24, CR3C26 and CR3C30



For use with Convect-Rite III® and Convect-Rite 3® INSIGHT docking stations

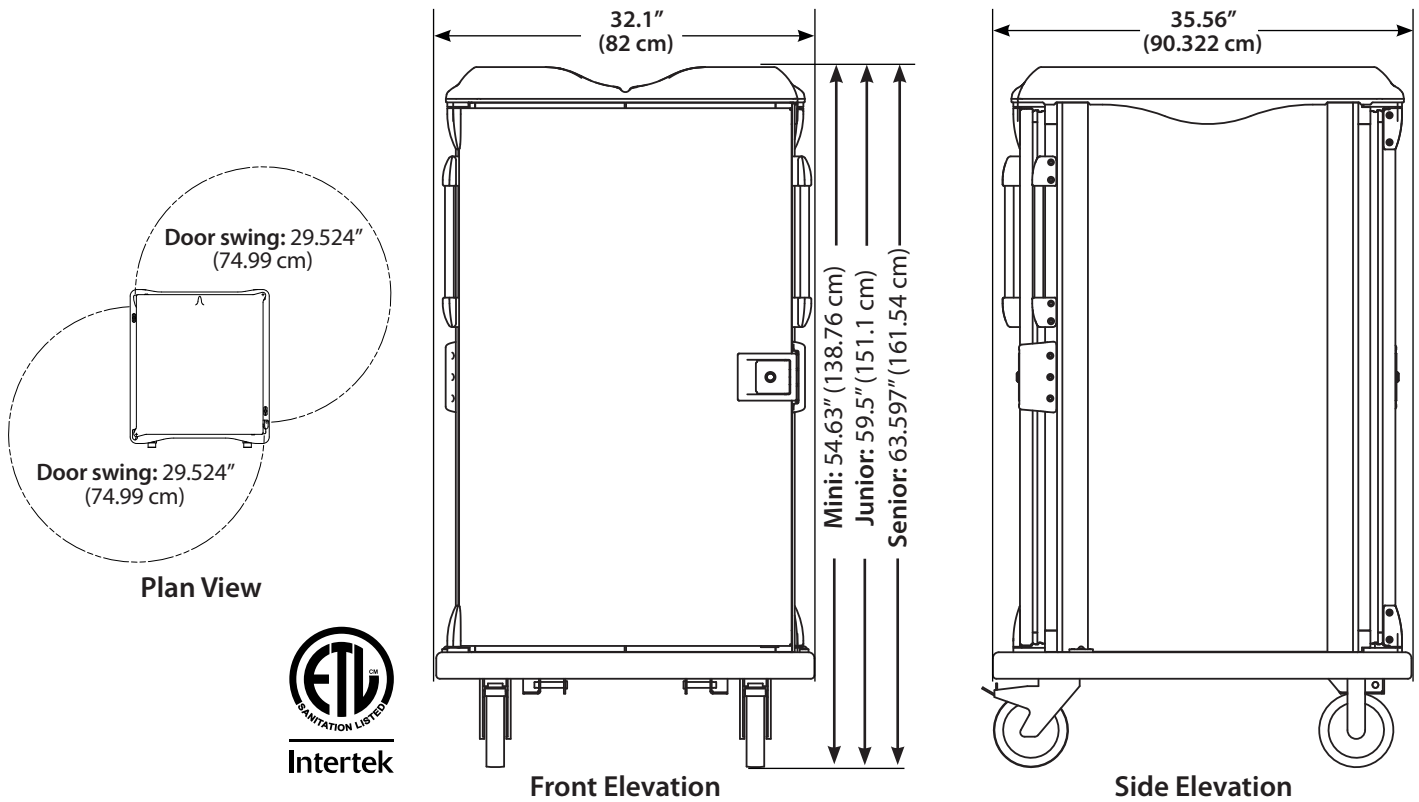

Convect-Rite® Tray Cart Features, Dimensions and Weight Data						
Cart Model Number <sup>1</sup>	<input type="checkbox"/> CR3C20002 Mini Cart	<input type="checkbox"/> CR3C24002 Mini Cart	<input type="checkbox"/> CR3C24001 Junior Cart	<input type="checkbox"/> CR3C26001 Senior Cart	<input type="checkbox"/> CR3C30001 Senior Cart	Cart and Dock (in docked configuration)
Tray capacity	20 Trays	24 Trays	24 Trays	26 Trays	30 Trays	
Tray guide spacing	3.6" (9.14 cm)	3.1" (7.874 cm)	3.5" (8.89 cm)	3.5" (8.89 cm)	3.1" (7.874 cm)	
Length	35.56" (90.32 cm)	35.56" (90.32 cm)	35.56" (90.32 cm)	35.56" (90.32 cm)	35.56" (90.32 cm)	57.5" (146.1 cm)
Width	32.125" (81.597 cm)	32.125" (81.597 cm)	32.125" (81.597 cm)	32.125" (81.597 cm)	32.125" (81.597 cm)	41" (104.1 cm)
Height	54.63" (138.76 cm)	54.63" (138.76 cm)	59.5" (151.1 cm)	63.597" (161.54 cm)	63.597" (161.54 cm)	
Weight	337 lbs. (152.9 kg)	337 lbs. (152.7 kg)	390 lbs. 176.9 kg)	403 lbs. (182.8 kg)	403 lbs. (182.8 kg)	
Shipping weight	357 lbs. (161.9 kg)	357 lbs. (161.9 kg)	410 lbs. (186 kg)	423 lbs. (191.9 kg)	423 lbs. (191.9 kg)	
Cart turning radius: 41.75" (106 cm)						

### Cart options:

- Cart wash caster configuration    
  Retractable tow hitch    
  Locking door latches    
  Transport latch

Visit [aladdintemprite.com/patents](http://aladdintemprite.com/patents) for patent information.  
 250 E. Main St. | Hendersonville, TN 37075 | Customer Service: 800.888.8018 | Tech Service: 800.888.5426 | Fax: 888.812.9956 | [aladdintemprite.com](http://aladdintemprite.com)  
 ©2023 Aladdin Temp-Rite.® All rights reserved. Note: Specifications are subject to change without notice.



S12623CR3C Rev-2

